

數位化轉型

AIM 企業資產維運平台

產品銷售服務處  
陳紓嫻 Shania



# CONTENTS

- 使用者需求
- Solution 方案
- 案例分享

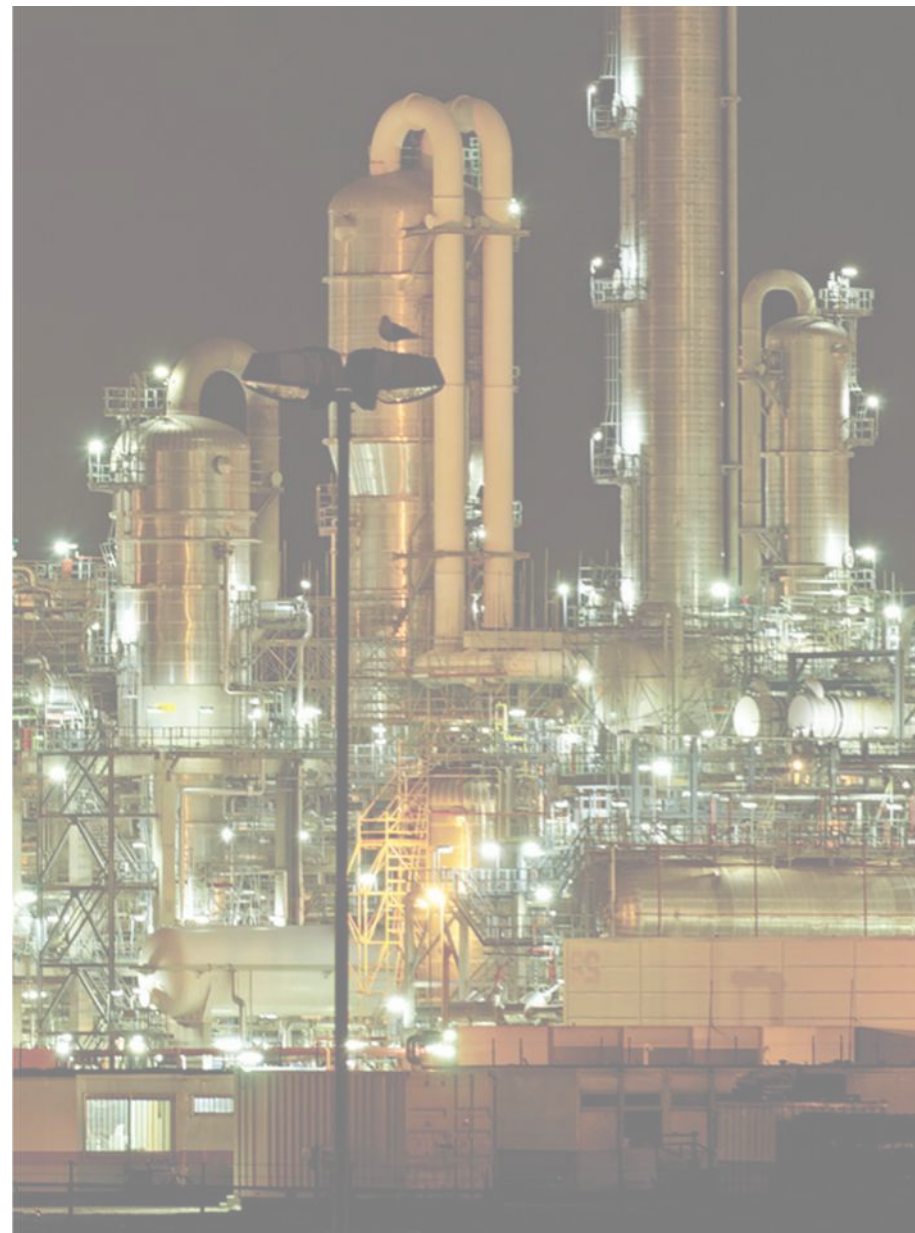

# 使用者需求

The background of the slide features a dark blue, semi-transparent image of a person's hand holding a smartphone. Overlaid on this image is a white line graph with an upward-pointing arrow, symbolizing growth or progress. The overall aesthetic is professional and tech-oriented.

## 使用者需求

- 隨時間越長，相關建廠設計紙本資料數量眾多不易查找
- 現場管線與設計資料不符
- 製程流程圖與現況不符
- 設備變更資料登載不齊全
- 勞檢局PSM 稽核需求



# 製程安全管理 PSM (Process Safety Management)

事業單位對經檢查機構審查合格之工作場所，應於製程修改時或至少每五年重新評估第五條檢附之資料，為必要之更新及記錄，並報請檢查機構備查。

PSM之主要目的：

- 辨識、評估及控制製程之潛在危害，強化製程之安全性
- 預防火災、爆炸、外洩等重大事故發生
- 降低事故之衝擊或影響
- 確保人員的安全與健康





# 製程安全管理 PSM (Process Safety Management)

## 製程安全管理作業之演進

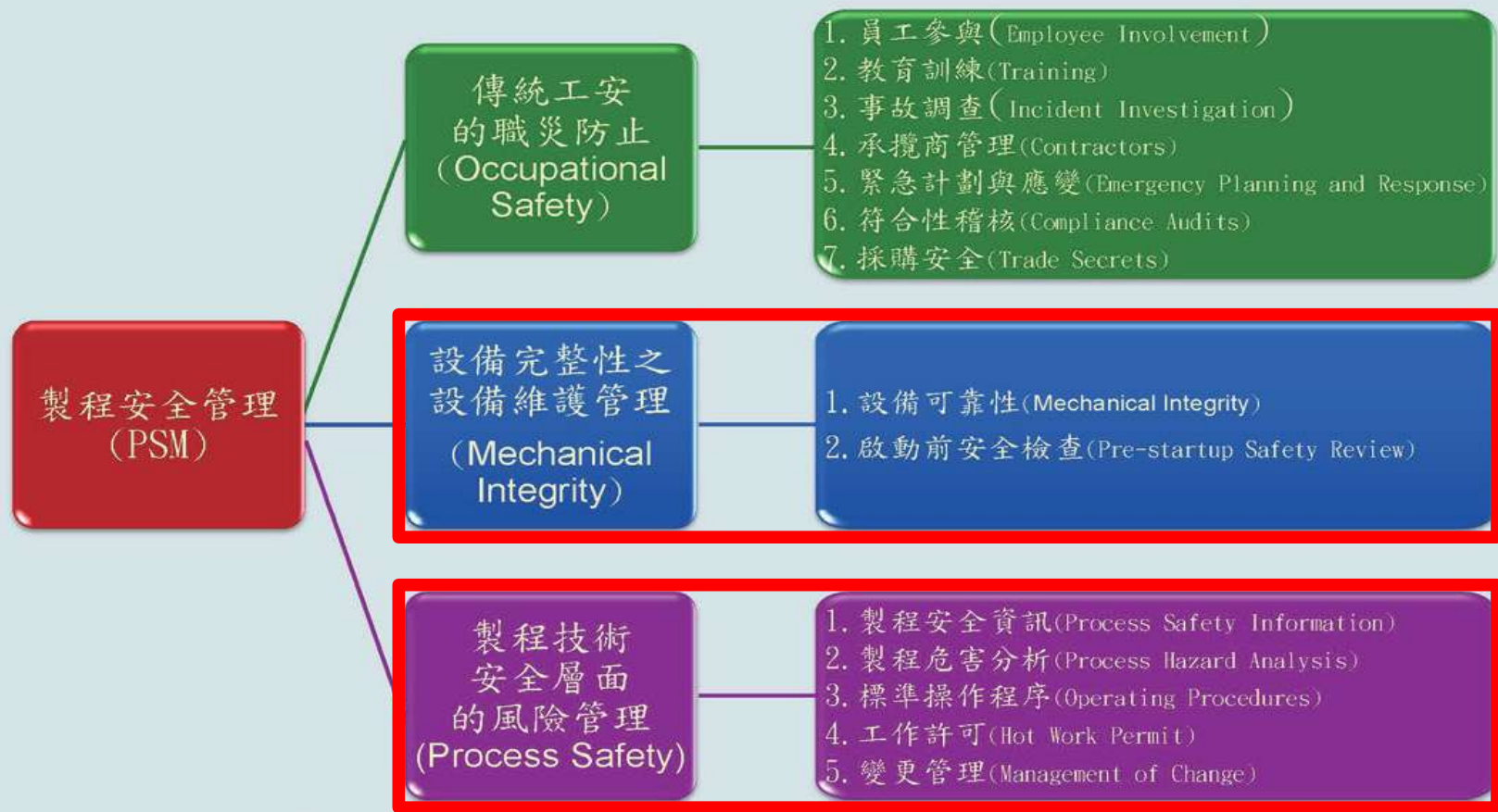

# 設備RBI (風險基準檢查評估)

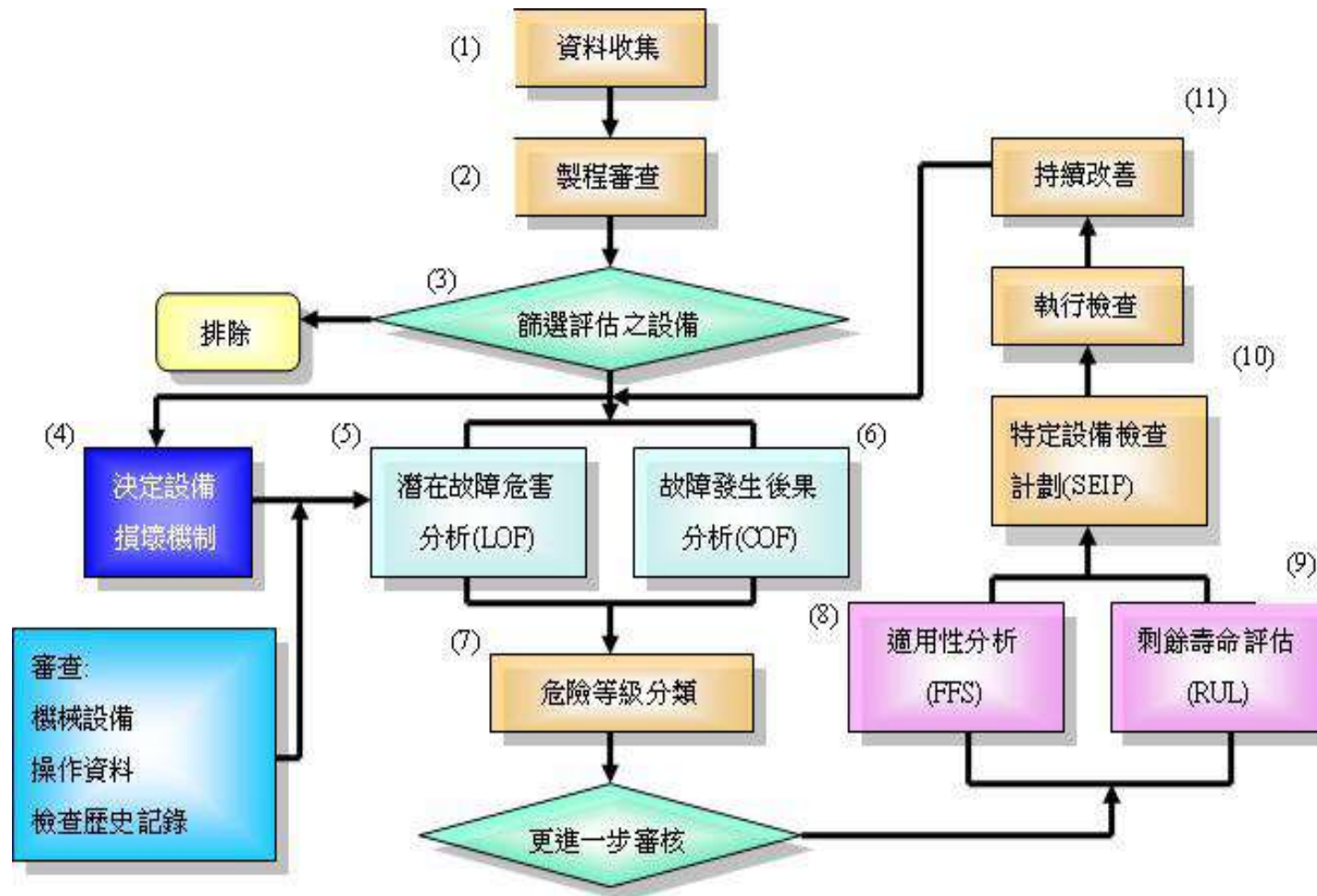

# 製程資料蒐集

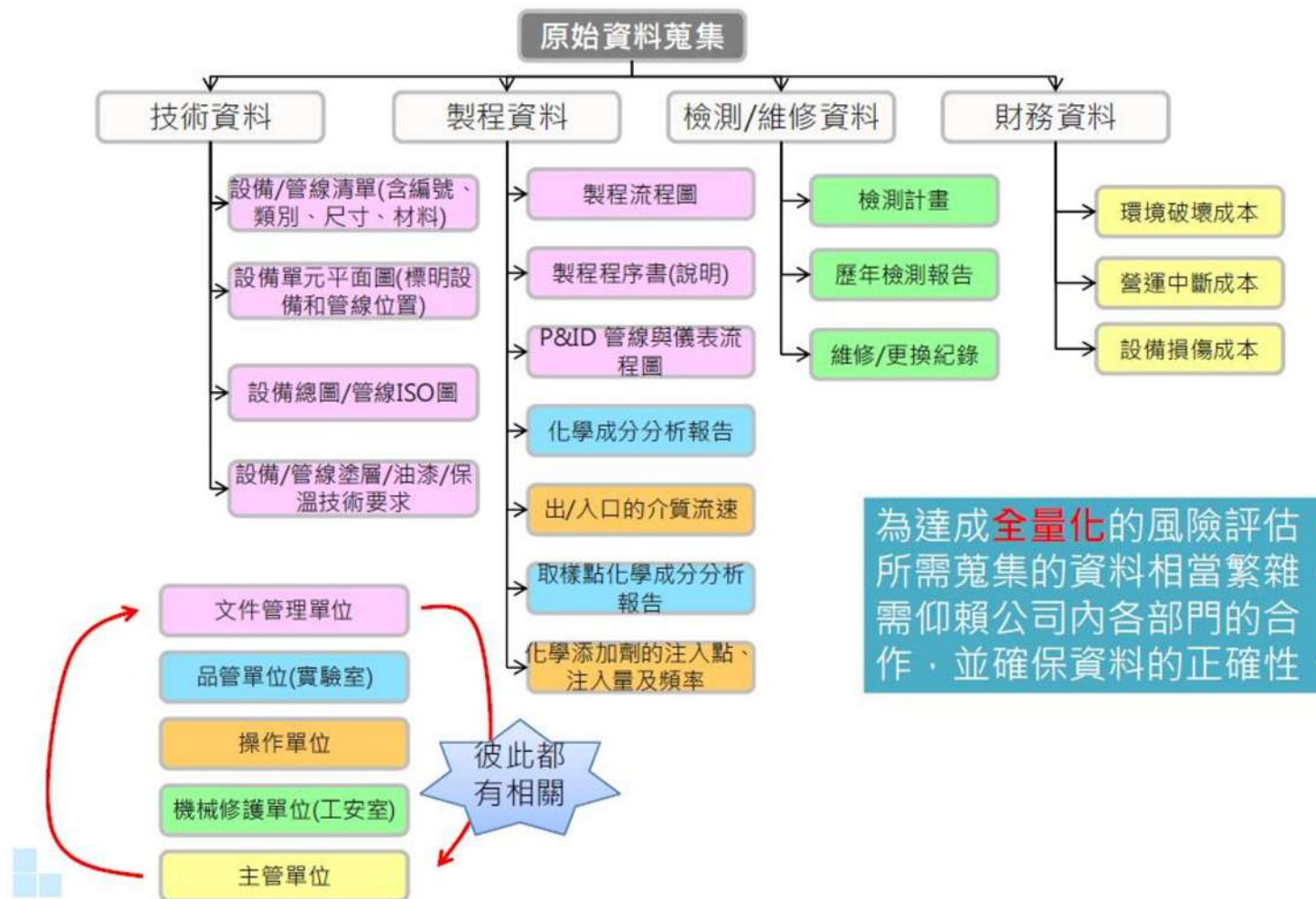



The background features a dark blue gradient with a faint line graph and a hand pointing towards the right. A teal wave shape is positioned at the bottom right corner. In the top left corner, there is a light grey triangle pointing right.

# Solution 方案

# 逆向工程 → 鐳射掃描

## 3D laser scanning

AVEVA WORLD CONFERENCE

**Laser Scanning**

- Efficient
- Affordable
- Automated

Status Quo:  
**Capture - 3D Overview**

DIGITALISATION: GETTING IT RIGHT

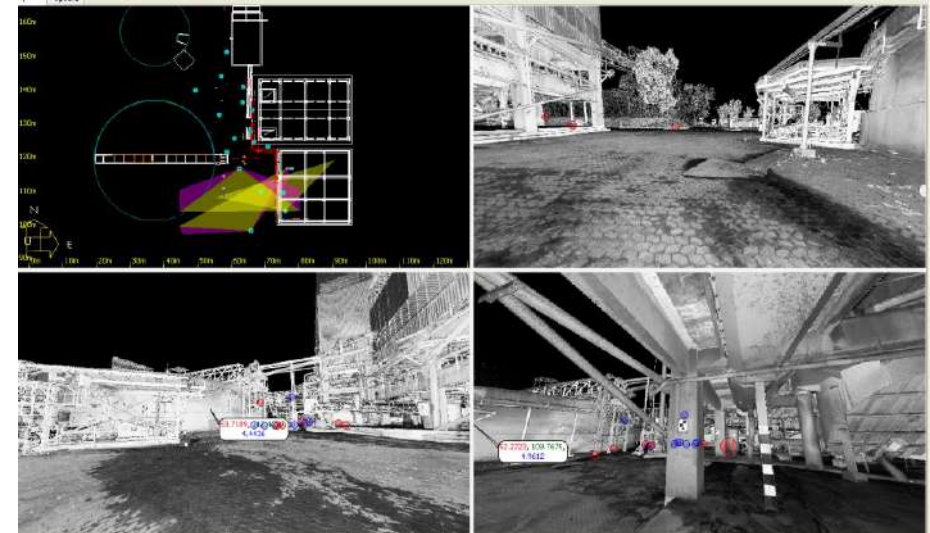
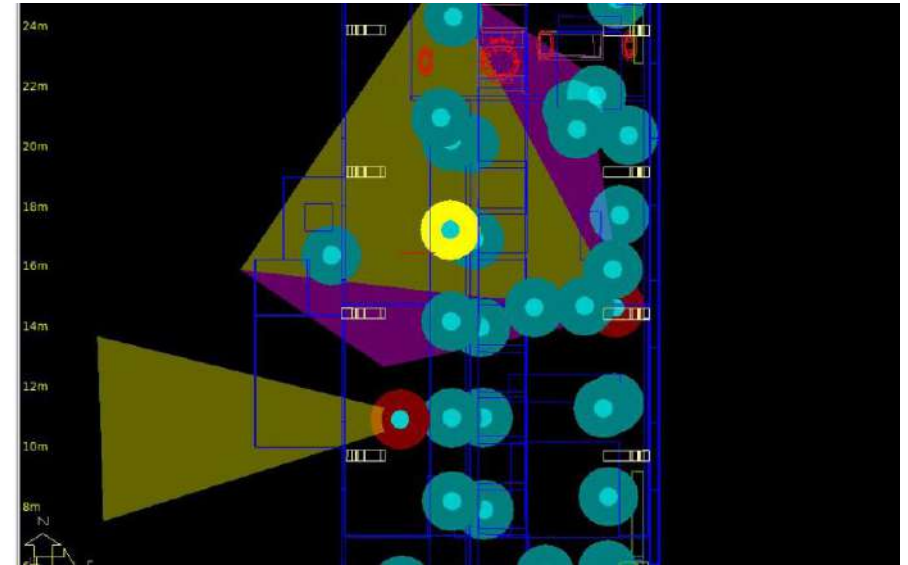



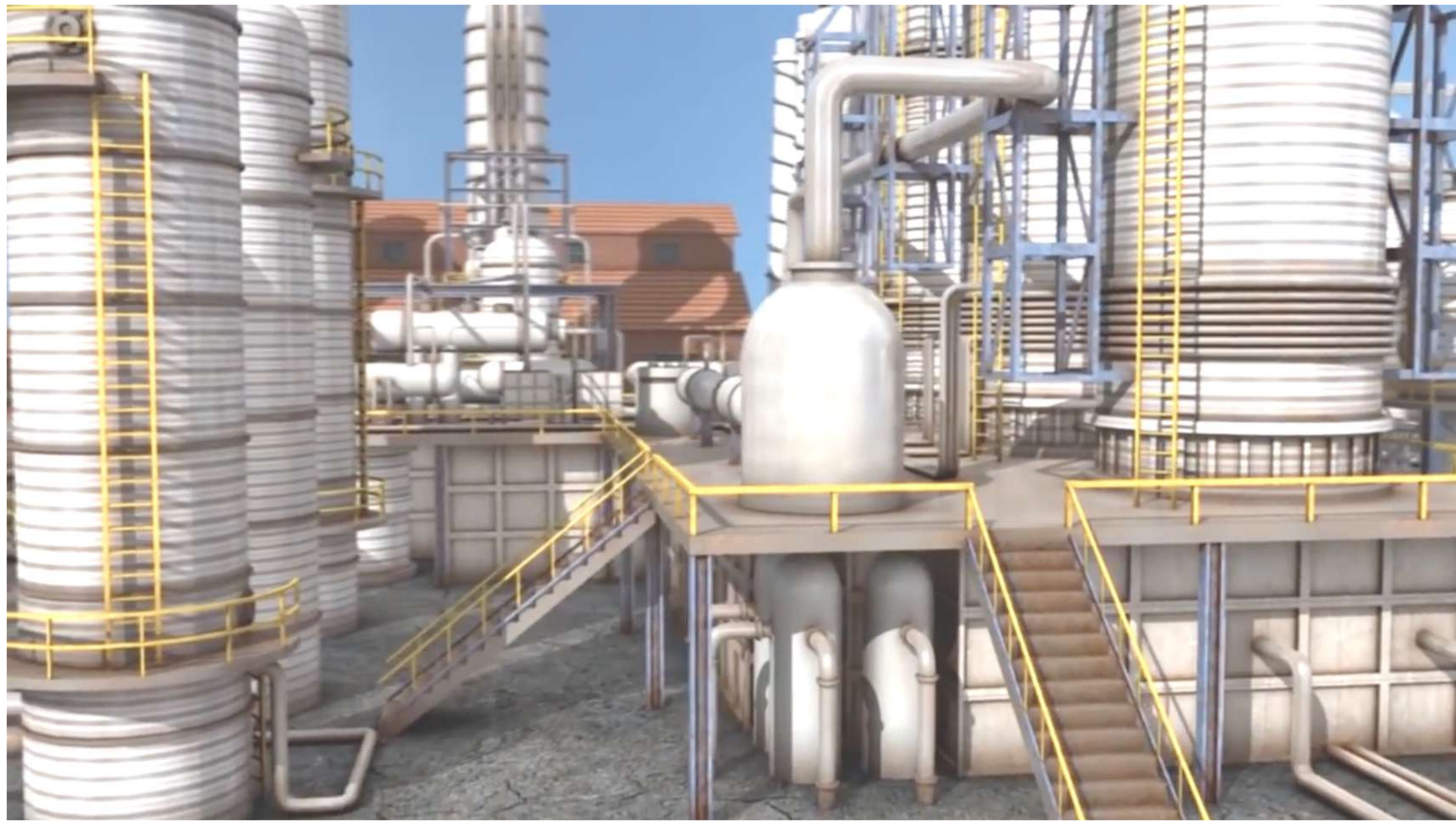

AVEVA NET Dashboard

net\_empty:16000/?portalId=Demo#/item/Demo%7C912/Demo%7C%252FA1A-01-80mmA%252FB-2

Dashboard CHECK\_page3 /A1A-01-80mmA/B-2 912

912 (3D MODEL) 1 Markup Print... Tools...

Navigation: Selection View Annotation: More Click and drag to orbit about center.

AVEVA NET Dashboard

PROJECT HOME VIEW  
Graphics  
Auto-Colour  
Current View  
Monochrome  
Settings

- KIP000001
- HOME MODEL
- SITE 001
  - ZONE 001PIPE
  - PIPE 001PIPE
    - BRANCH1
    - FLAN 1
    - FLAN 2
    - FLAN 3
    - FLAN 4
    - DASK 1
    - DASK 2
    - DASK 3
    - DASK 4
- SITE 010-STR
- SITE 010-PIPE
- SITE 010-DCI
- SITE SAMPLE\_Layer
  - ZONE 1
  - XOCHON EATOR
  - SITE ELE\_TEST
  - SITE 7
  - SITE 8
  - SITE YAC
  - SITE 10
  - SITE 11
  - SITE YU
  - SITE CRW
  - DRINK-1
  - SITE STL\_TEST
  - SITE 10wel
  - SITE TBA7M
  - SITE 24
  - SITE Tml
  - SITE 910
  - SITE 20
  - SITE ATP

# AVEVA Diagrams

Process Flow Diagrams (PFDs) 製程流程圖

Piping and Instrumentation Diagrams (P&IDs) 管線與儀表圖

Heating, Ventilation and Air Conditioning (HVAC) 空調系統

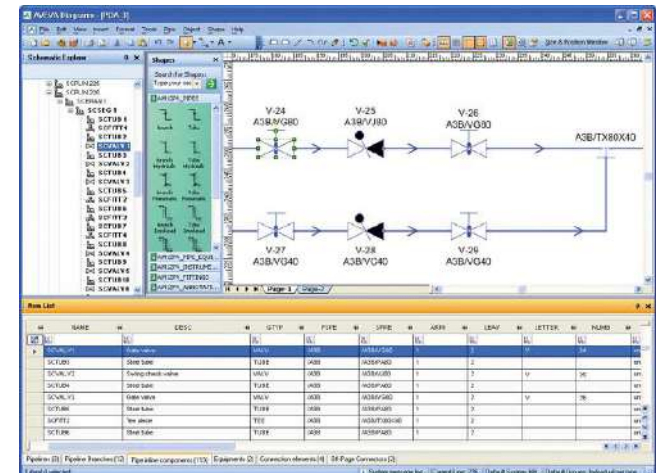
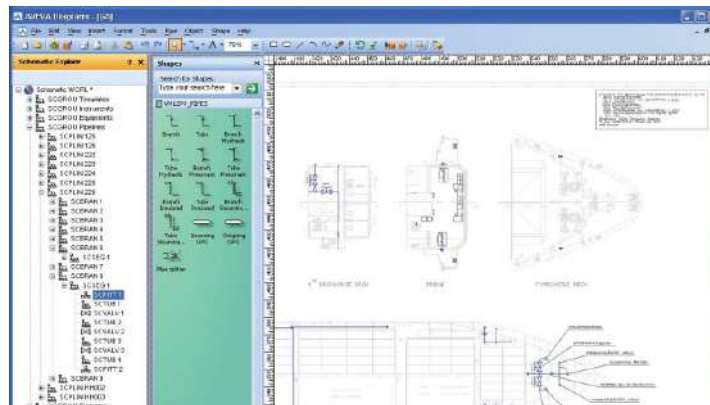
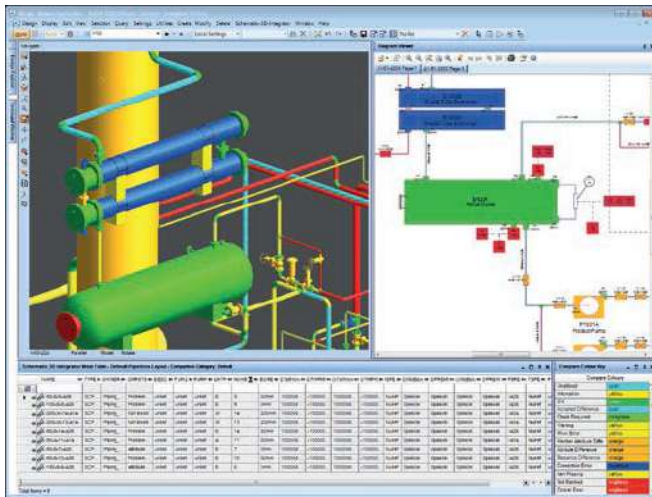



# 製程與設備3D模型整合

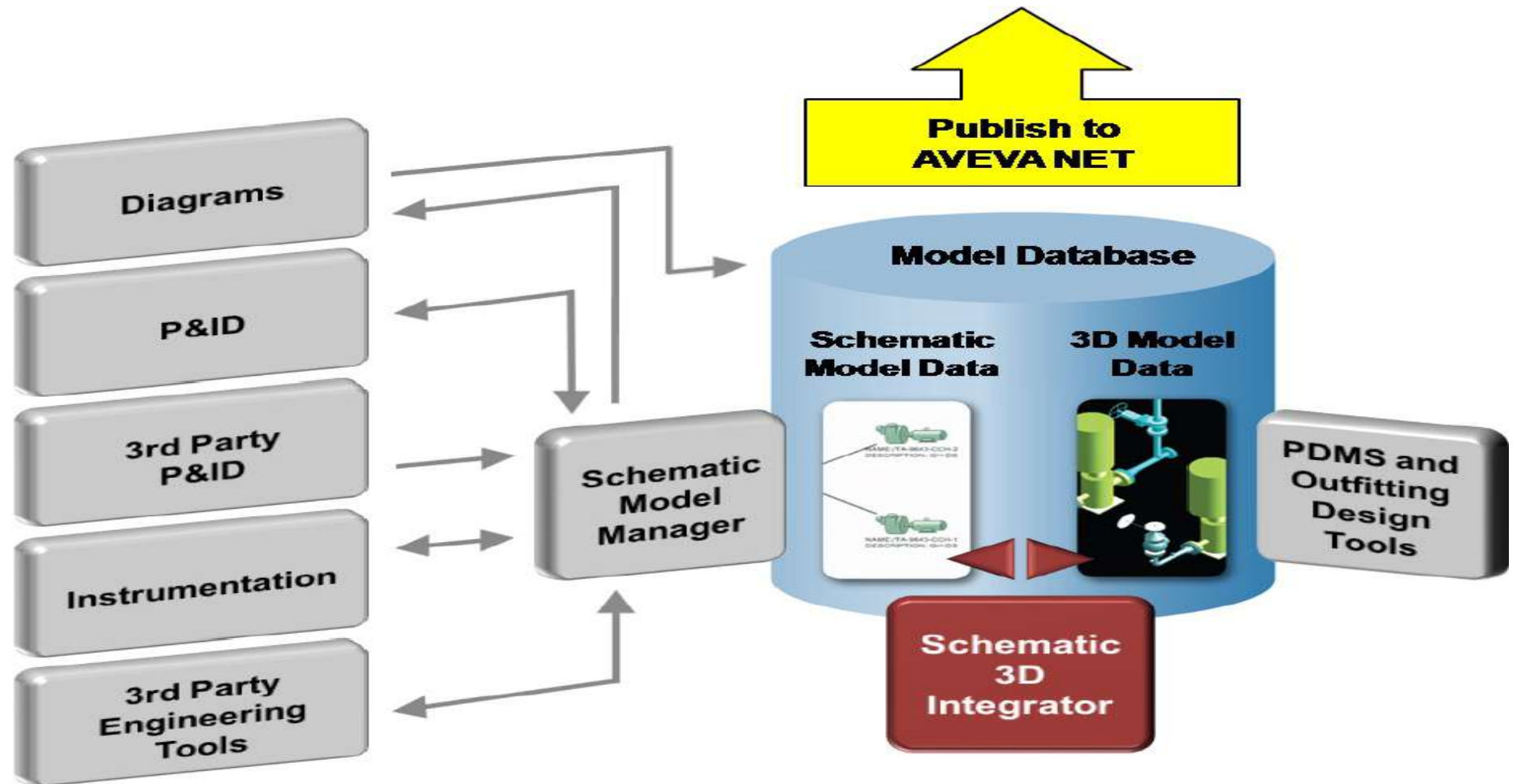



# 設備資料完整性

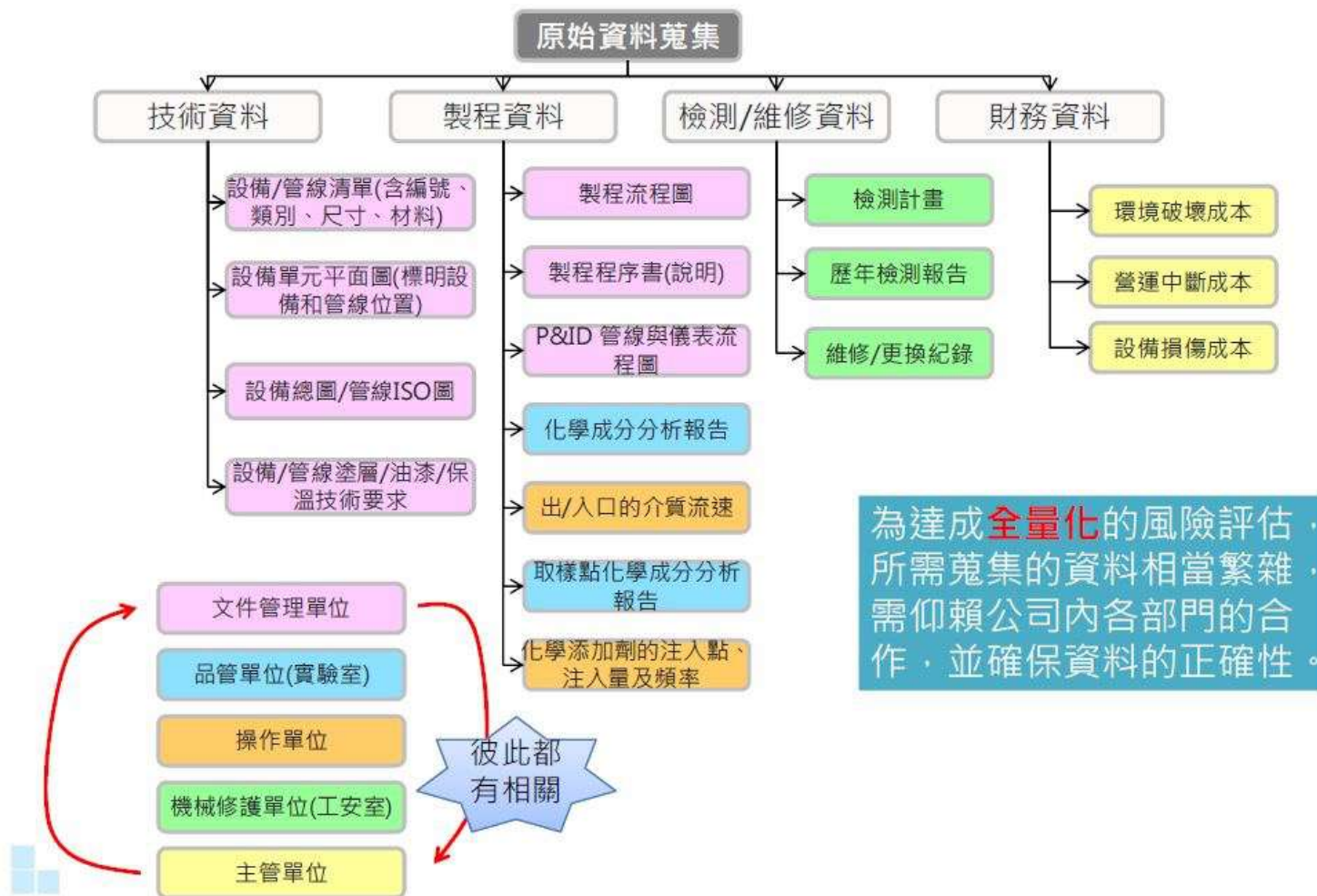



AIM

企業資產維運平台

原理圖



鐳射掃描模型



文檔系統



資料庫

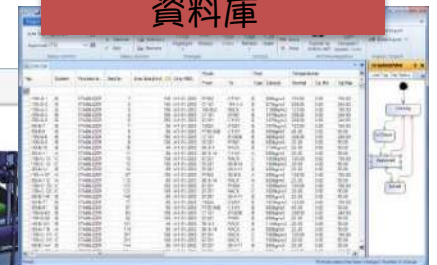

地理資訊



SAP

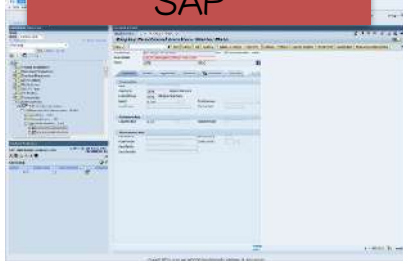

專案計畫



運營維護資料



單管圖

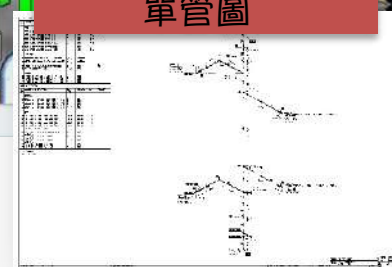

三維模型



加工圖



資料表



# 案例分享



## 專案內容

- 全區雷射掃描(範圍60,000 m<sup>2</sup>)
- 4,000根檢測管件及600個設備
- 3D建模與建屬性/點雲處理及轉檔/點雲建模
- DIAGRAMS 繪製指定管線之P&ID，設定P&ID所示廠區設備、閥、ISO管線與廠區E3D模型對應物件之連結。
- AVEVA NET (AIM管理平台) Implement導入及安裝

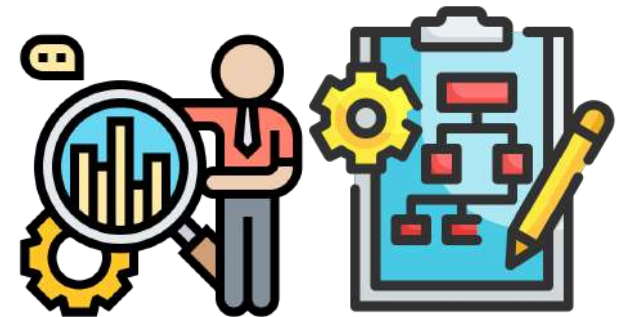

# 專案工作流程

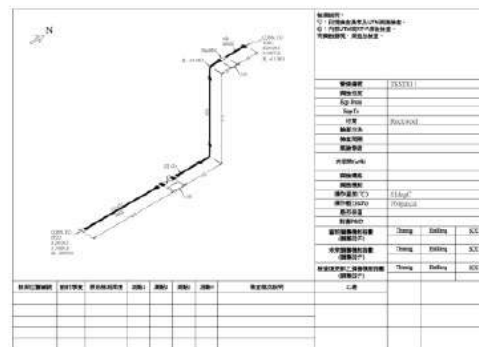

雷射掃描

3D建模

建立P&ID模型  
連結關係

利用3D模型  
出圖

匯入AVEVA  
NET

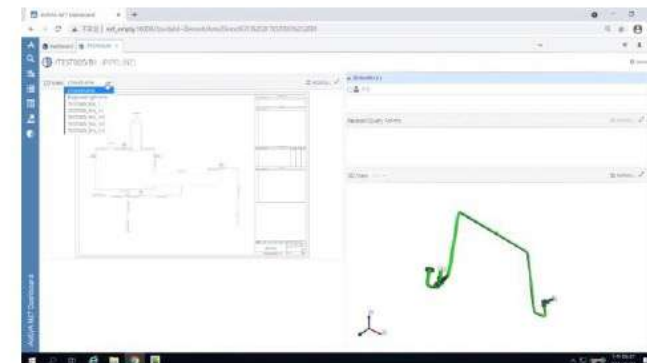
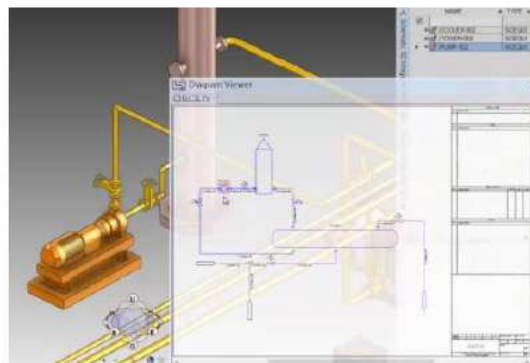



## 解決方案中...

➤ 引人注目的事件:

- 操作容易，功能齊全，符合需求。

➤ 獨特的商業價值:

- 相關建廠設計紙本資料關聯
- 現場管線與設計資料對應
- 製程流程圖與設備連動
- 設備變更資料歸檔
- 設備維護資料整合/AI預測性保養

➤ 對用戶有什麼好處:

- PSM 稽核需求 ( AIM / LFM / E3D / Diagrams)
- 符合法規/資料備查



## 數位化延伸效益

20% 減少管子現場焊接

5% 減少材料浪費

20% 減少工程時間

70% 減少現場工作

95% 減少返工 (無模型間碰撞)



鑄射資產

一體化  
協同設計

施工  
交付物

數位化  
交付運維



## 總結

高效精準

高質  
快速  
協同

準確智能

完整標準

鑄射資產

改建一體化  
協同設計

施工交付物

數位化交付  
運維



 **科勝科技**  
UTITECH TECHNOLOGY CO.,LTD.



**THANK YOU !**  
Smart Technologies Driving Tomorrow's Production.